

JK BMS bluetooth Manual

cherry@3apower.com

Tel/whatsapp:86-13924612941

1.1 Main technical indicators

The main technical indicators of the protection board are shown in

Table 1.

Table 1 Main technical indicators of protection board

Spec	Model			
	BD6A20S10P	B1A24S15P	B2A24S15P	B2A24S20P
li-ion battery series	14~20s	14~24s	14~24s	14~24s
Lifepo4 battery series	16~20s	16~24s	16~24s	16~24s
LTO battery series	20s	20~24s	20~24s	20~24s
Wrie output	Charge and discharge same port			
Single cell voltage	1~5 V			
Voltage acquisition	±5 mV			
Continuous discharge current	100A	150A	150A	200A
Maximum discharge current	200A	300A	300A	350A
Balanced way	active			
Balance current	0.6 A	1 A	2 A	2 A
internal resistance	0.8mΩ	0.5mΩ	0.5mΩ	0.3mΩ
Overcharge protection voltage	1.2~4.25 V adjustable			
Overcharge release voltage	1.2~4.25 V adjustable			
Charging overcurrent protection (adjustable)	10~100 A	10~150 A	10~150 A	10~200 A
Charge overcurrent release time	2~120S adjustable			
Over discharge protection voltage	1.2~4.25 V adjustable			
Overdischarge recovery voltage	1.2~4.25 V adjustable			
Discharge over current protection (adjustable)	10~100 A	10~150 A	10~150 A	10~200 A
Discharge overcurrent release time	2~120S adjustable			
Number of temperature detection	3pcs			

Temperature protection	have
Short circuit protection	have
Coulomb counter	have
Bluetooth	Support Android IOS
GPS (Optional)	support
Other interfaces (customized)	RS485/CAN

1.2 Environmental conditions

a) Operating temperature range: $-20^{\circ}\text{C} \sim 70^{\circ}\text{C}$;

b) Power requirements: 40~100V.

c) Power consumption: 10mA@100V in balanced state, 6mA@100V in unbalanced state.

2.Connector and interface description

2.1Connector and LED light position description

The position of the connector and LED light is shown in Figure

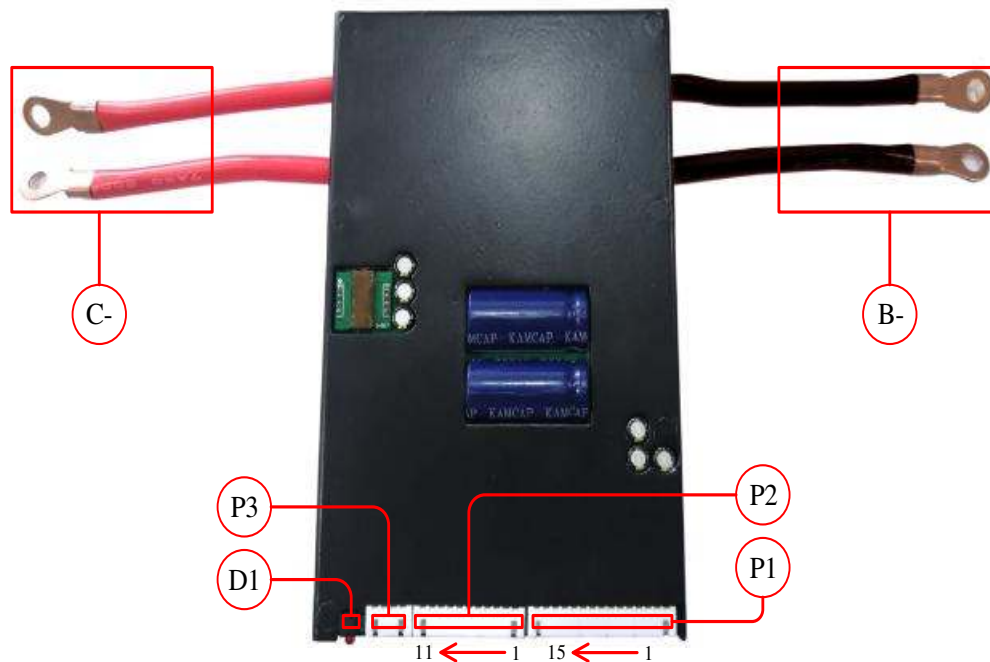

Connector	Pin number	JK-BD6A20S-10P		JK-B1A24S-15P/JK-B2A24S-15P/JK-B2A24S-20P	
		Name	definition	name	definition
P1	1	B-	Total negative electrode of battery	B-	Total negative electrode of battery
	2	B1	1 st cell +	B1	1 st cell +
	3	B2	2 nd cell +	B2	2 nd cell +
	4	B3	3 rd cell +	B3	3 rd cell +
	5	B4	4 th cell +	B4	4 th cell +
	6	B5	5 th cell +	B5	5 th cell +
	7	B6	6 th cell +	B6	6 th cell +
	8	B7	7 th cell +	B7	7 th cell +
	9	B8	8 th cell +	B8	8 th cell +
	10	B9	9 th cell +	B9	9 th cell +
	11	B10	10 th cell +	B10	10 th cell +
	12	B11	11 th cell +	B11	11 th cell +
	13	B12	12 th cell +	B12	12 th cell +
	14	B13	13 th cell +	B13	13 th cell +
	15	B14	14 th cell +	B14	14 th cell +
P2	1	B15	15 th cell +	B15	15 th cell +
	2	B16	16 th cell +	B16	16 th cell +
	3	B17	17 th cell +	B17	17 th cell +
	4	B18	18 th cell +	B18	18 th cell +
	5	B19	19 th cell +	B19	19 th cell +
	6	B20	20 th cell +	B20	20 th cell +
	7	B+	BMS power	B21	21 st cell +
	8	-	-	B22	22 th cell +
	9	-	-	B23	23 rd cell +
	10	-	-	B24	24 th cell +
	11	-	-	B+	BMS power
P3	1	T1A	The first temperature sensor A pin		
	2	T1B	The first temperature sensor B pin		
	3	T2A	The second temperature sensor A pin		
	4	T2B	The second temperature sensor B pin		
D1	Bluetooth connection indicator, the indicator light is always on when the Bluetooth is connected to the protection board, and the indicator light flashes when the connection is disconnected.				
C-	Connect to external load or negative pole of charger				
B-	Connect the negative pole of the battery				

3.1 Wiring diagram

The intelligent lithium battery protection board is suitable for lithium battery packs with 14-24 strings of cells. The wiring method of battery packs with different numbers of cells is different.

For the battery pack with 24 strings of cells in series, the installation and wiring method is shown in the figure.

Wiring diagram

24s bms

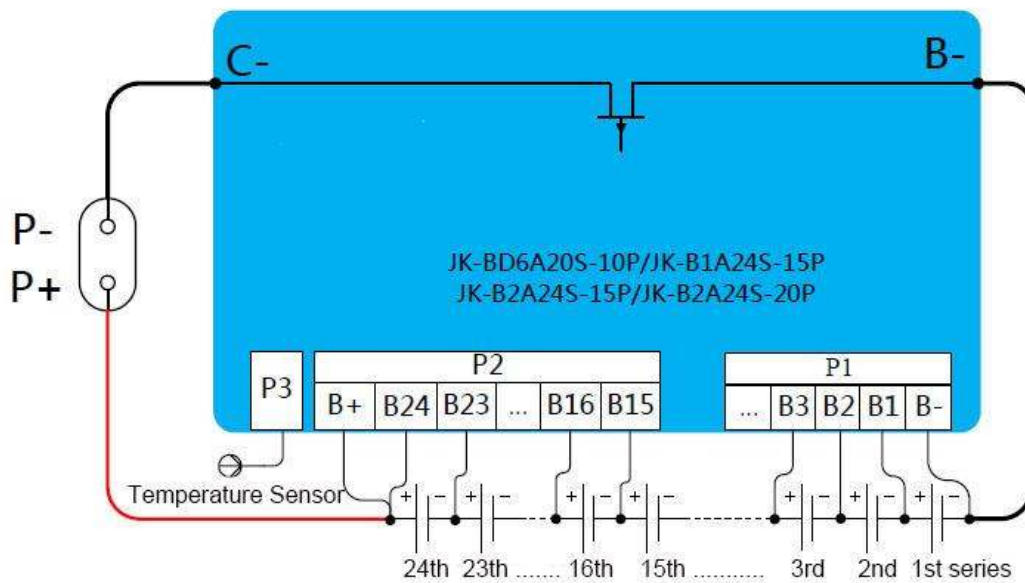

23s bms

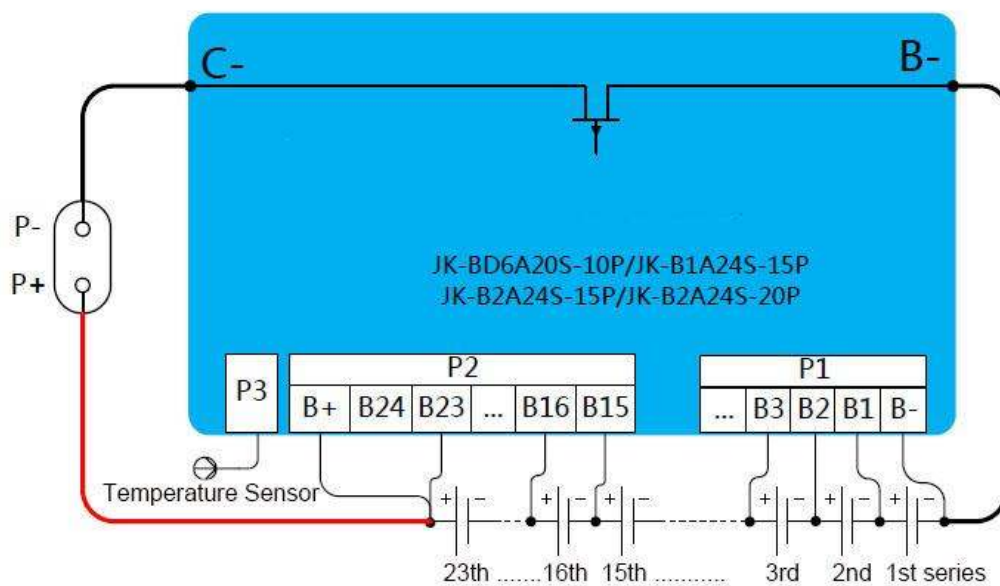

22s bms

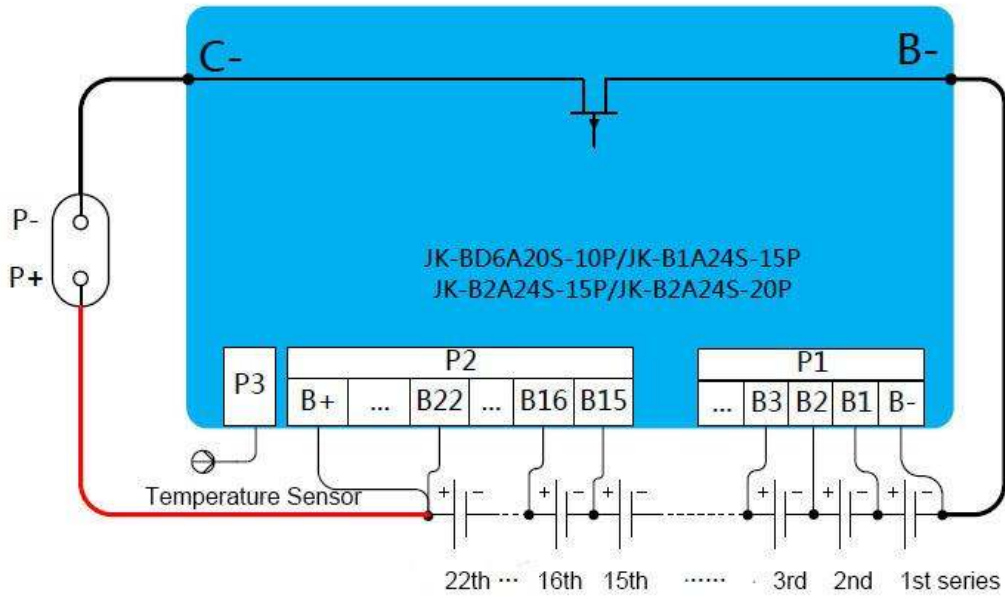

20s bms

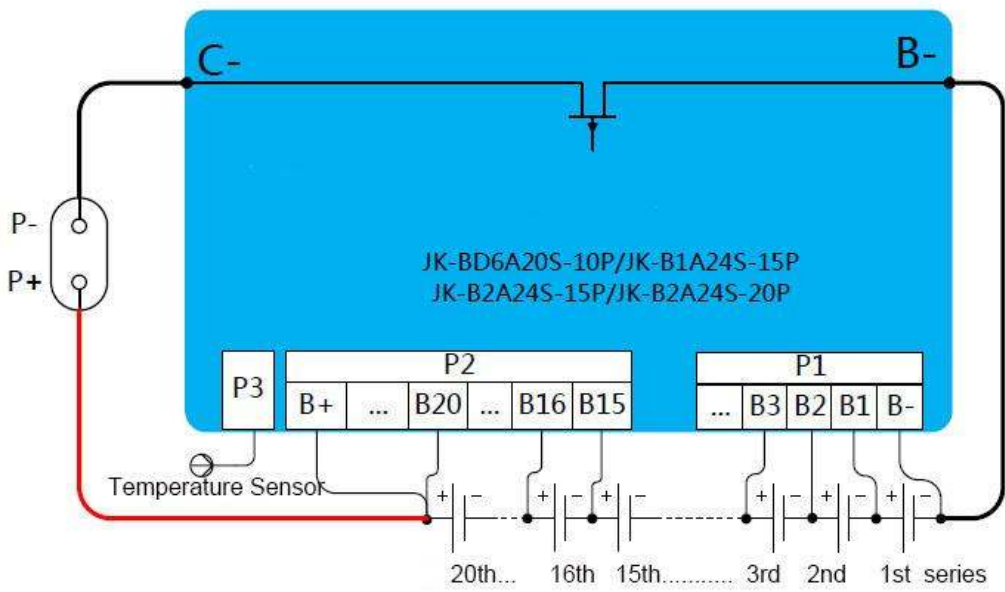

17s bms

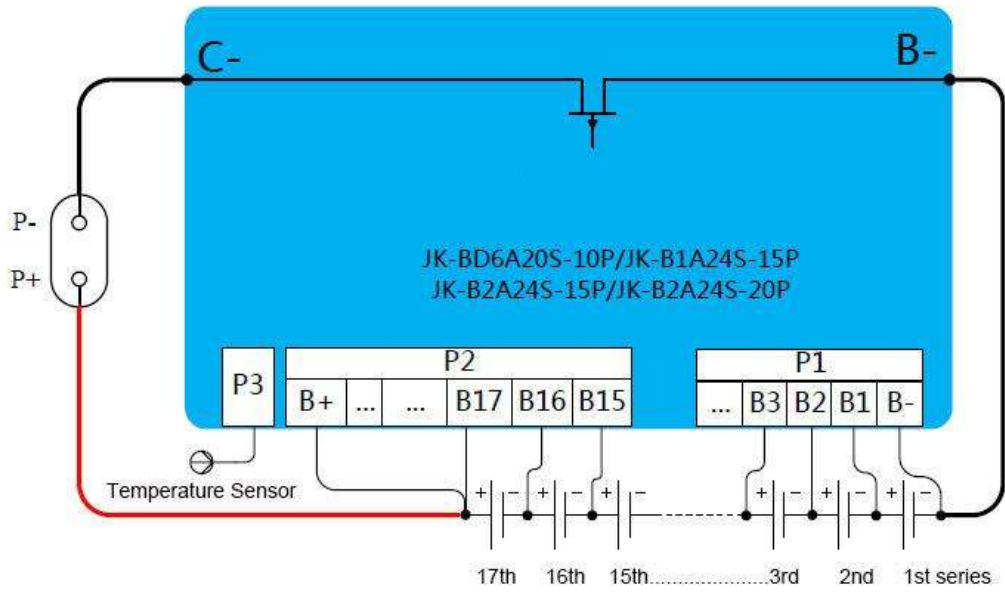

16s bms

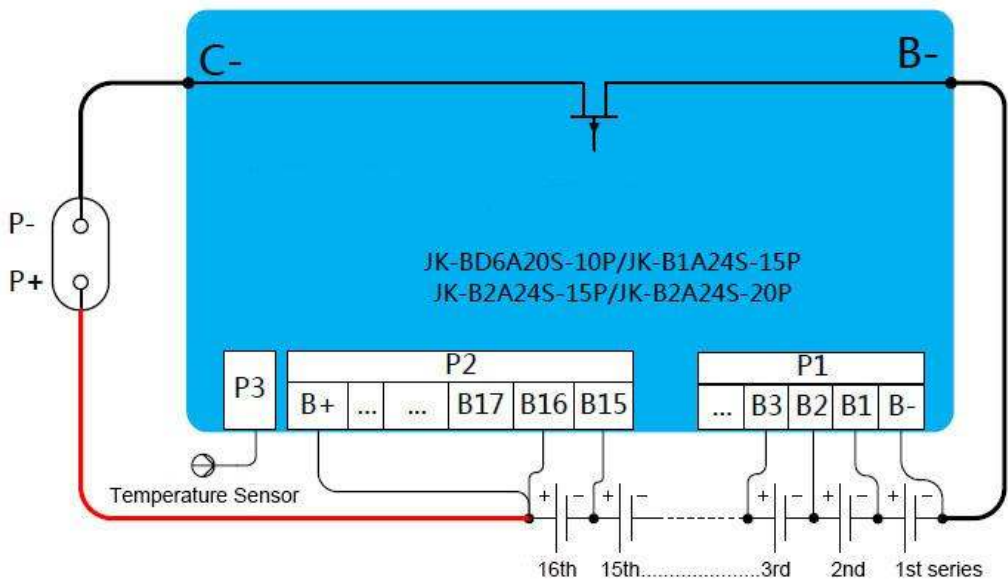

14S BMS connect

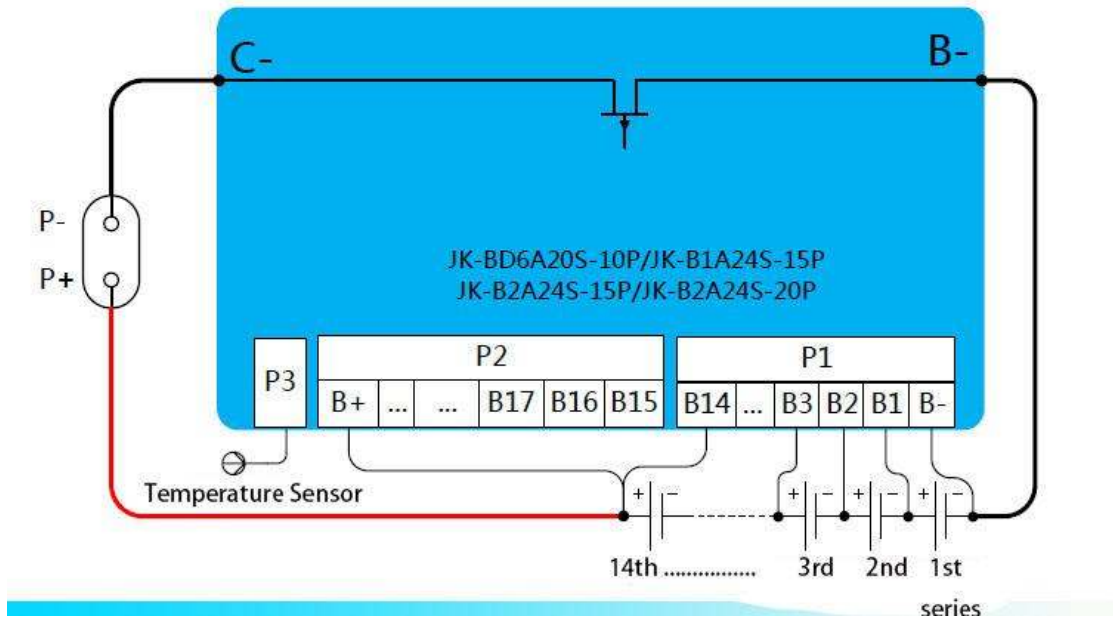

3.2 Install APP, Scan this QR to download app



Check whether the protection board has been securely fixed with the battery cell, and only after confirming that it is correct, can the protection board be connected to power, otherwise it may cause serious consequences such as abnormal operation or even burnout.

4.1 The protection board works

After confirming that the above operations are correct, you can power on the protection board. The protection board does not have a power-on control switch, and it is designed as a charging activation mode, that is, after the battery is assembled, a charger needs to be connected to make the protection board work.

4.2 APP operation instructions

4.2.1 Equipment operation

a) Device connection

First turn on the mobile phone's Bluetooth, then open the APP, as shown in Figure .

Click the icon in the upper left corner to scan the device.

After the scan is completed, click the name of the device to be connected, such as "JK-B1A24S".

The APP will prompt to enter the password when connecting for the first time.

The default password of the device is "1234".

After the device is connected, the APP will automatically record the password.

You do not need to enter the password for the next connection.

The APP will automatically connect after opening the APP.

The password input interface is shown in the figure.

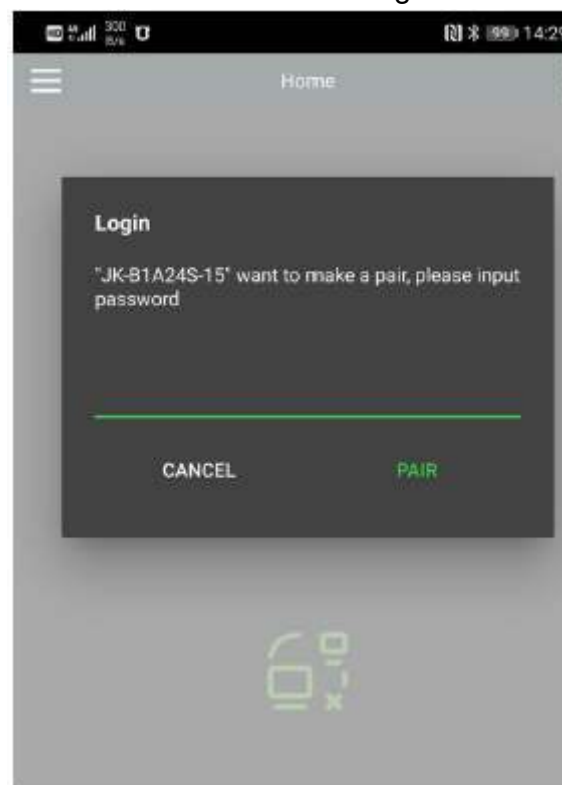

b) Modify password and name

After the device is connected, click the "pen" icon on the right side of the device list to modify the device name and password.

The interface for modifying the device name is shown in Figure 15. Note that the device name only supports English or numbers, not Chinese names and Chinese characters.

The password modification interface is shown in Figure 16. To modify the device password, you must first enter the device's old password. Only when

the current password is correct, can you enter the new password input option. After entering the new password twice, click "OK" to complete the device password modification.

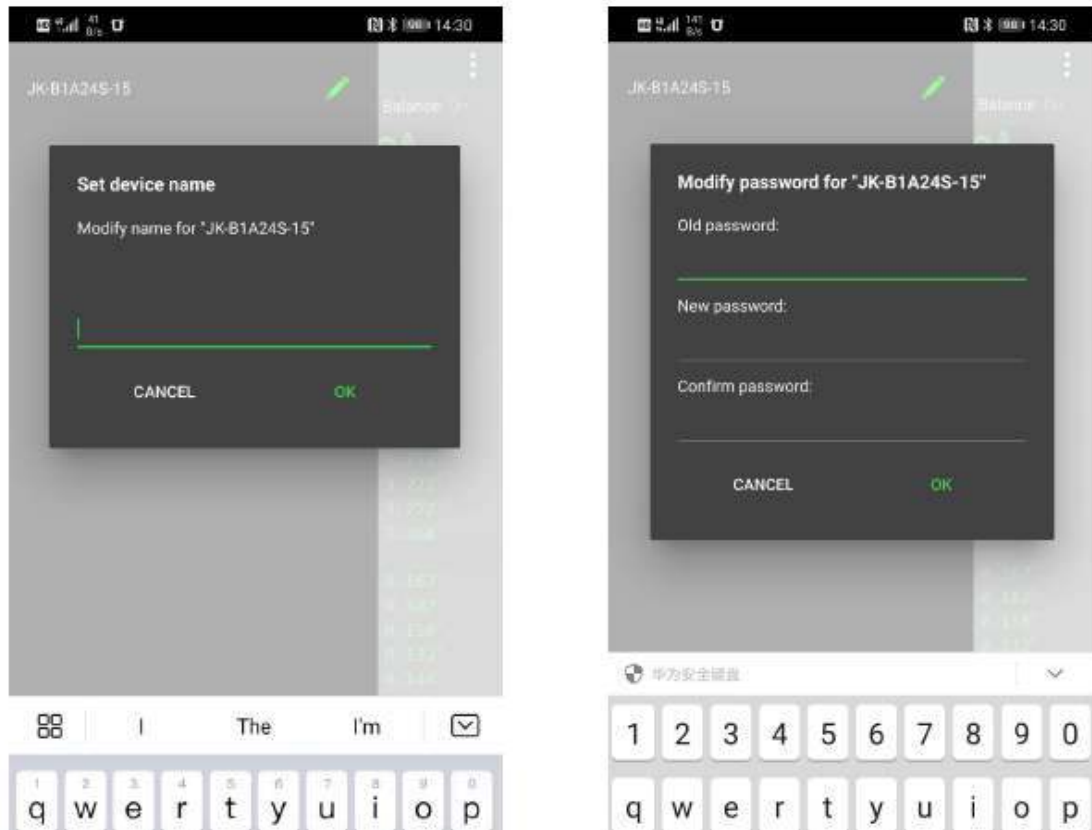

4.3. Status View

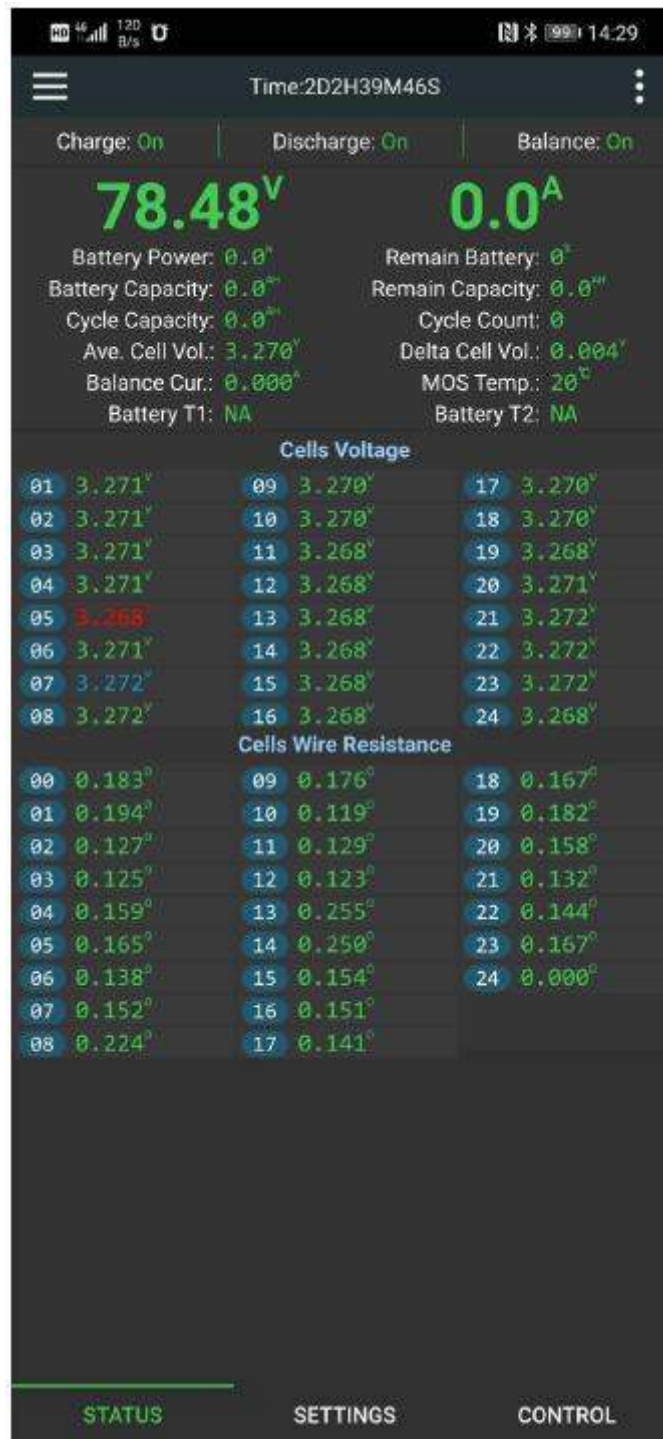

The real-time status page is divided into 3 areas.

Area 1 in the figure is the battery comprehensive information column. The definition of each parameter is as follows:

a) **Running time**

The running time represents the total running time since the protection board was turned on the first time.

b) **Charging**

Indicates the current on state of the charging MOS of the protection board.

When it displays "on", it means that the current protection board charging MOS is on and the battery is allowed to charge; when it displays "off", it means the current protection board charging MOS is off and the battery is not allowed to charge.

c) Discharge

Indicates the on state of the current protection board discharge MOS. When it displays "on", it means that the current protection board discharge MOS is open and the battery is allowed to discharge; when it displays "off", it means the current protection board discharge MOS is off and the battery is not allowed to discharge.

d) Balance

Indicates the current on state of the equalization switch of the protection board. When "ON" is displayed, the protection board will automatically balance when the equilibrium starting condition is reached; when "OFF" is displayed, the balance is off, and the protection board will not balance the battery.

e) Voltage

The voltage area displays the current total voltage of the battery in real time, and the total voltage is the sum of all cell voltages.

f) Current

The current area displays the current total current of the battery in real time. When the battery is charged, the current is positive, when the battery is discharged, the current is negative.

g) Battery power

Represents the total power output or input of the current battery, and its value is the product of the current battery voltage and the absolute value of the battery current.

h) Remaining battery

Indicates the current percentage of battery power remaining.

i) Battery capacity

Represents the actual battery capacity calculated by the high-precision SOC of the current protection board, and the unit is AH. (This value needs to be updated after the battery has completed a complete discharge and charge cycle).

j) Remaining capacity

The remaining capacity represents the remaining capacity of the current battery, unit: AH.

k) Cycle capacity

Cycle capacity represents the cumulative discharge capacity of the battery, unit: AH.

l) Number of cycles

The number of cycles indicates the number of times that the current battery is fully charged, and the unit is: times.

m) Single average

Indicates the average voltage of the current battery cell, unit: V.

n) **Maximum pressure difference**

The maximum voltage difference represents the difference between the highest cell voltage and the lowest cell voltage of the current whole battery group, unit: V.

o) **Balance current**

When the protection board turns on the equalization function and the equalization condition is reached, the equalization current is displayed in real time, in A.

When the balance is in progress, the real-time status status display area, blue represents the discharged battery, red represents the charged battery. The negative current of the equalization current indicates that the battery is discharging, and the blue flashes at this time, and the positive current of the equalization current indicates that the battery is charging, and the red flashes at this time.

The protection board uses active equalization technology. The principle of balance is to take electricity from the high-voltage cell, store it in the protection board, and then put it on the low-voltage cell.

p) **MOS temperature**

Real-time display the current temperature of the protection board power MOS, unit: °C.

q) **Battery temperature 1**

When the temperature sensor 1 is not installed, "NA" is displayed. When the temperature sensor is installed, the temperature of the temperature sensor 1 is displayed in real time, in °C.

r) **Battery temperature 2**

When the temperature sensor 2 is not installed, "NA" is displayed. When the temperature sensor is installed, the temperature of the temperature sensor 2 is displayed in real time, in °C.

In the figure, area 2 is the cell voltage area. Real-time display of the voltage data of each cell in the battery pack, where red represents the cell with the lowest voltage and blue represents the cell with the highest voltage.

Area 3 in the figure is the equalizing line resistance area. The equalizing line resistance is the equalizing line resistance obtained by the self-check of the protection board. This value is only a rough calculation. The purpose is to prevent wrong wiring or poor contact. When the equalizing line resistance exceeds a certain value, it will be displayed in yellow. Cannot turn on equalization.

4.3.1 **Parameter setting**

The parameter setting page is shown in Figure 18.

Various working parameters of the protection board can be modified on the parameter setting page. The definition of each parameter is as follows.

a) **One key iron lithium**

Function This button can modify all the working parameters of the protection board to iron-lithium battery parameters. The default values of the parameters are shown in Appendix 1.

b) One key triple

Function This button can modify all the working parameters of the protection board to the iron-lithium battery parameters. The default values of the parameters are shown in Appendix II.

c) Number of monomers

The number of cells indicates the number of cells of the current battery. Please set this value accurately before use, otherwise the protection board will not work normally.

d) Battery capacity

This value is the design capacity of the battery.

e) Trigger equalizing pressure difference

The trigger equalization pressure difference is the only parameter that controls the equalization. When the equalization switch is turned on, when the maximum pressure difference of the battery pack exceeds this value, the equalization starts and ends when the pressure difference falls below this value. For example, set the equalization trigger voltage difference to 0.01V, when the battery pack voltage difference is greater than 0.01V, the equalization will begin, and the equalization will end when the voltage drop is below 0.01V. (It is recommended to set the equalized trigger pressure difference for batteries above 50AH to 0.005V, and set the equalized trigger pressure difference for batteries below 50AH to 0.01V).

f) Voltage calibration

The voltage calibration function can be used to calibrate the accuracy of the equalizer voltage acquisition.

When it is found that there is an error between the total voltage collected by the protection board and the total voltage of the battery, you can use the voltage calibration function to calibrate the protection board. The method of calibration is to fill in the total battery voltage currently measured, and then click on the "small plane" behind the voltage calibration to complete the calibration.

g."Monomer undervoltage protection", "monomer undervoltage recovery"

"Single undervoltage protection" refers to the cut-off voltage of the cell. As long as the voltage of any cell in the battery pack is lower than this value, a "cell undervoltage alarm" is generated, and the protection board turns off the discharge MOS. At this time, the battery cannot Discharge, only charge. When the alarm is generated, only after the voltage values of all cells exceed the value of "cell voltage recovery", the protection board releases the "cell

undervoltage alarm" and turns on the discharge MOS at the same time.

h) "Cell overcharge voltage", "cell overcharge recovery"

"Cell overcharge voltage" refers to the saturation voltage of the battery cell. As long as the voltage of any cell in the battery pack exceeds this value, a "cell overcharge alarm" will be generated, and the protection board will turn off the charging MOS, and the battery cannot be charged at this time, Can only discharge. When the alarm is generated, only after the voltage values of all cells are lower than the value of "cell overcharge recovery", the protection board will release the "cell overcharge alarm" and turn on the charging MOS at the same time.

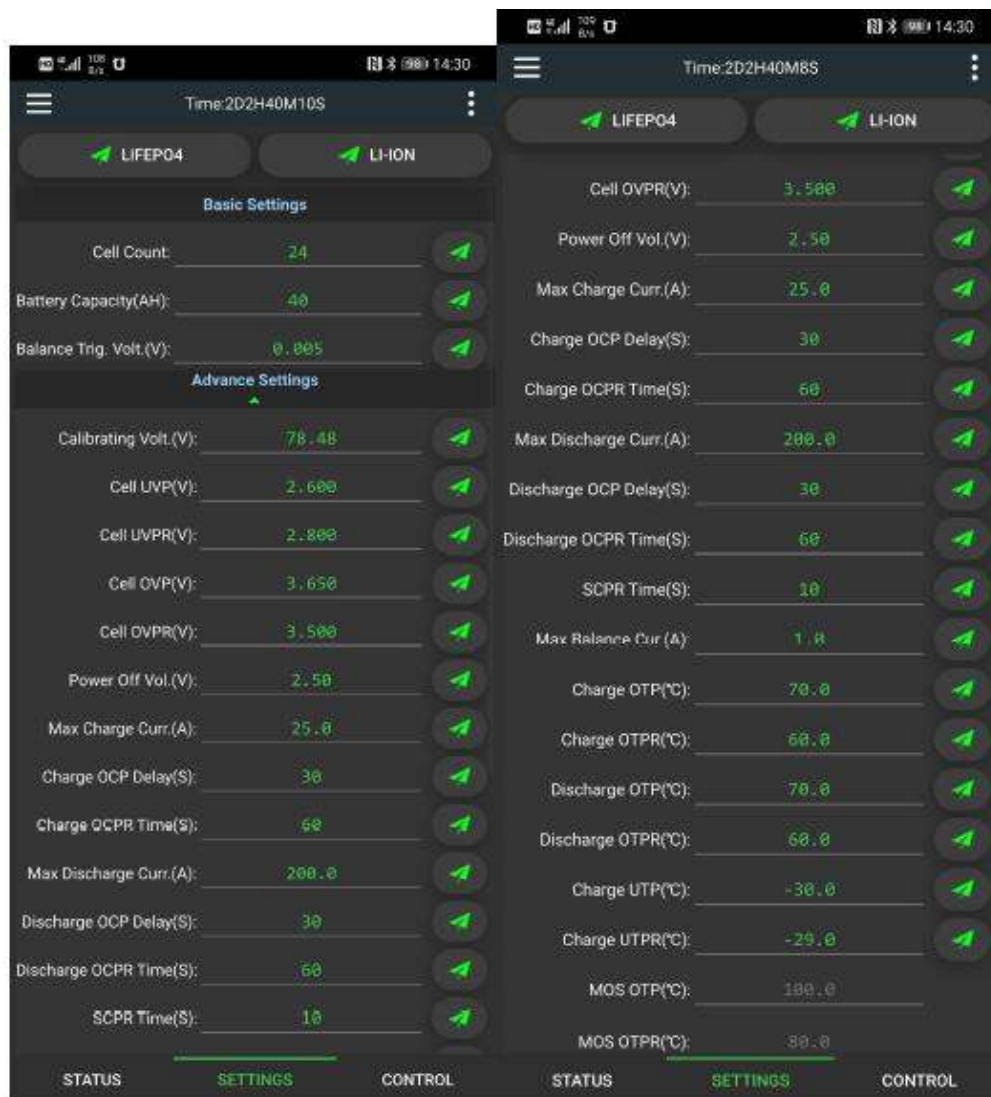

i) Automatic shutdown voltage

The automatic shutdown voltage represents the lowest voltage at which the protection board works. When the voltage of the highest cell in the battery pack is lower than this value, the protection board is turned off. This value must be

lower than "Single undervoltage protection".

j) "Maximum charge current", "charge overcurrent delay", "charge overcurrent release"

When charging the battery pack, if the current exceeds the "maximum charging current" and the duration exceeds the "charging overcurrent delay" time, the protection board generates a "charging overcurrent alarm" and turns off the charging MOS. After the alarm is generated, after the "charge overcurrent release" time has elapsed, the protection board releases the charge overcurrent alarm and restarts the charging MOS.

Example: Set "Maximum charging current" to 10A, "Charge overcurrent delay" to 10 seconds, and "Charge overcurrent release" to 50 seconds. During the charging process, if the charging current exceeds 10A continuously for 10 seconds, the protection board will generate a 'charging overcurrent alarm' and at the same time turn off the charging MOS. 50 seconds after the alarm is generated, the 'charging overcurrent alarm' will be released and the protection board will restart the charging MOS.

k) "Maximum discharge current", "Discharge overcurrent delay", "Discharge overcurrent release"

When discharging the battery pack, if the current exceeds the "maximum discharge current" and the duration exceeds the "discharge overcurrent delay" time, the protection board will generate a "discharge overcurrent alarm" and turn off the discharge MOS. After the alarm is generated, after the "discharge overcurrent release" time, the protection board releases the "discharge overcurrent alarm" and restarts the discharge MOS.

Example: Set "Maximum discharge current" to 100A, "Discharge overcurrent delay" to 10 seconds, and "Discharge overcurrent release" to 50 seconds. During the discharge process, if the discharge current exceeds 100A for 10 seconds, the protection board will generate a 'discharge overcurrent alarm' and turn off the discharge MOS. 50 seconds after the alarm is generated, the 'discharge overcurrent alarm' will be released and the protection board will restart the discharge MOS.

l) Short circuit protection released

When the short-circuit protection occurs, the short-circuit protection will be released after the time set by the "short-circuit protection release".

m) Maximum balance current

The equalization current represents the continuous current of high-voltage battery discharge and low-voltage battery charging in the process of energy

transfer.

The maximum balance current represents the maximum current in the energy transfer process, and the maximum balance current should not exceed 0.1C. For example: 20AH battery does not exceed $20 \times 0.1 = 2A$.

n) "Charging over temperature protection", "charging over temperature recovery"

During the charging process, when the battery temperature exceeds the value of "charging over-temperature protection", the protection board will generate a warning of "charging over-temperature protection" and the protection board will turn off the charging MOS. After the alarm is generated, when the temperature is lower than the "charging over temperature recovery", the protection board will release the "charging over temperature protection" warning, and at the same time restart the charging MOS.

o) "Charging low temperature protection", "Charging low temperature recovery"

During the charging process, when the battery temperature is lower than the value of "charging low temperature protection", the protection board will generate a "charging low temperature protection" warning, and the protection board will close the charging MOS. After the alarm is generated, when the temperature is higher than the "charging low temperature recovery", the protection board releases the "charging low temperature protection" warning, and at the same time restarts the charging MOS.

p) "MOS over temperature protection", "MOS over temperature recovery"

When the MOS temperature exceeds the value of "MOS over temperature protection", the protection board generates a "MOS over temperature alarm" and closes the charge and discharge MOS, and the battery cannot be charged or discharged. After the alarm is generated, after the MOS temperature is lower than the value of "MOS over temperature recovery", the protection board will release the "MOS over temperature alarm", and at the same time re-open the charge and discharge MOS (MOS over temperature protection value is 75 °C, MOS over temperature recovery value 65°C, these two values are factory default values and cannot be modified).

note:

For any parameter modification, please refer to the manual. Inappropriate parameters may cause the protection board to not work properly or even burn the protection board.

After any parameter is modified, you need to click the "little plane" behind the parameter to complete the parameter delivery. After the equalizer successfully receives the parameter, it will make a beep.

4.4 BMS control

The BMS control page is shown in the figure. Through BMS control, the charging function, discharging function, and equalizing function of the protection board can be switched, and the power supply of the protection board can be turned off, and the factory settings can be restored.

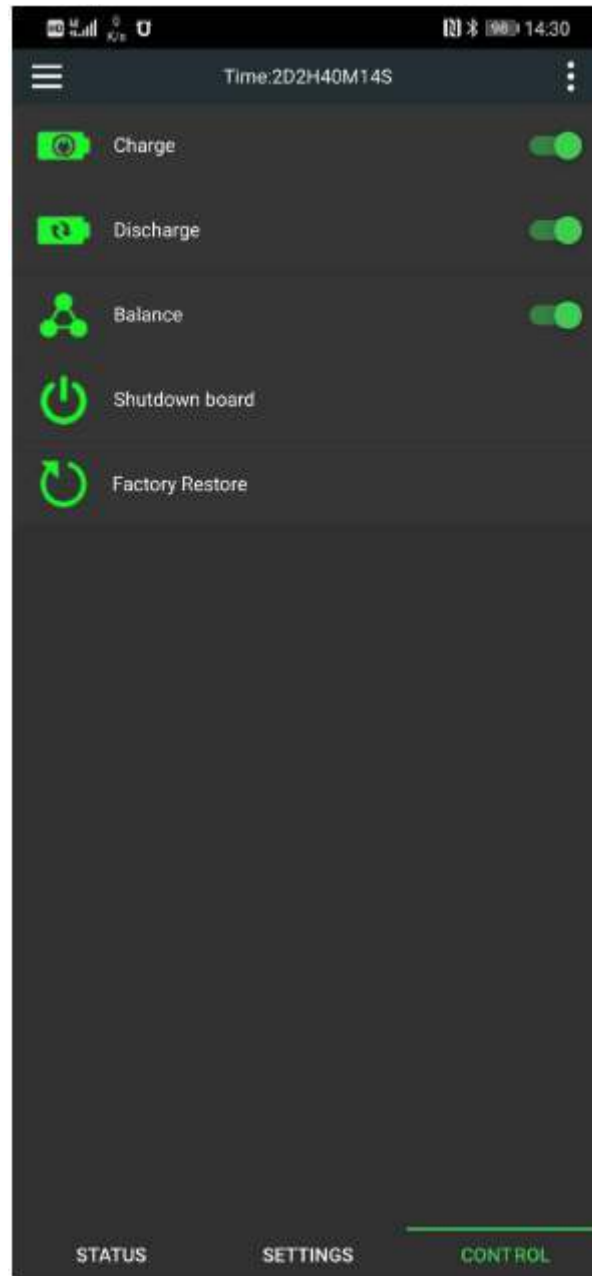

5 Safety protection measures and precautions

There is no high voltage in the protection board itself, which will not cause electric shock to the body.

Please read the instruction manual carefully before use, and connect the wires according to the correct wiring diagram with different numbers of strings.

Connect from the negative pole to the positive pole. After the equalization line is connected, use a multimeter to confirm again, and then insert the protection board after confirming that it is correct.

It is not allowed to modify the power line of the protection board without authorization. Modifying the power line without authorization will cause uneven overcurrent of the protection board and burn the protection board.

6 Transportation and storage

6.1 Transportation

The packed products are not directly affected by rain and snow, and can be transported by usual means of transportation. It is not allowed to put it together with corrosive substances such as acid and alkali during transportation.

6.2 Storage

The packaged products should be stored in a permanent warehouse. The temperature of the warehouse is $0^{\circ}\text{C} \sim 35^{\circ}\text{C}$, the relative humidity is not more than 80%. There should be no acid, alkali, corrosive gas, strong mechanism vibration and impact, and no strong magnetic field in the warehouse. The role of.

Appendix Default parameters of "One-key Lithium Iron", "One-key Ternary" and "One-key Lithium Titanate"

Item	Spec	li-ion	Lifepo4	LTO	unit
1	Single undervoltage	2.9	2.6	1.8	V
2	Single-unit undervoltage protection recovery	3.2	3.0	2.0	V
3	Single overcharge	4.2	3.6	2.7	V
4	Monomer overcharge protection recovery	4.1	3.4	2.4	V
5	Trigger equalizing pressure difference	0.01	0.01	0.01	V
6	Automatic shutdown voltage	2.8	2.5	1.7	V
7	Charge overcurrent protection delay	30	30	30	seconds
8	Charge overcurrent protection release time	60	60	60	seconds
9	Discharge overcurrent protection delay	30	30	30	seconds
10	Discharge overcurrent protection release time	60	60	60	seconds
11	Short circuit protection release time	60	60	60	seconds
12	Charging over temperature protection	60	60	60	°C
13	Charging over temperature recovery	55	55	55	°C
14	Discharge over temperature protection	60	60	60	°C
15	Discharge over temperature recovery	55	55	55	°C
16	Charging low temperature protection	-20	-20	-20	°C
17	Charging low temperature recovery temperature	-10	-10	-10	°C
18	MOS over temperature protection temperature	75	75	75	°C
19	MOS over temperature protection recovery temperature	70	70	70	°C